

DRAMM



Hydra™ 200

Owners Manual

Table of Contents

Warranty	4
Warning	5
Introduction	6
Assembly and Preparation	6
Operation	6-7
Start-Up.....	6
Spray Operation	7
Shut-Down	7
Chemical Mixing Procedure	8
Maintenance & Cleaning	8
Hydra 200 Cart Parts and Assembly Diagram	9
Hydra 200 Cart Parts List	10
Hose Reel and Gun Parts and Assembly Diagram	11
Plumbing Assembly Diagram	12
Plumbing and Hose Reel Parts List	13
OPTIONAL 20 gal Tank valve Operation	14
Agitation System	14
Hydra Brake Maintenance	15
Spray Gun	16
Spray Gun Parts List	17
Crank Case and Inlet Valve Parts and Assembly Diagram	18
Crank Case and Inlet Valve Parts List	19
Pressure Regulator Valve Parts and Assembly Diagram	20
Pressure Regulator Valve Parts List	21
Troubleshooting	22-23
Notes	24

DRAMM

Hydra 200™ Hydraulic Sprayer

- 5.5 HP Honda Gasoline Motor
- 1.5 HP Electric Motor

Serial Number

Limited Warranty

Dramm Corporation warrants, to the extent of the purchase price, that the Hydra 200™ will be free from defects in materials and workmanship to the original purchaser for a period of six months. Parts subject to wear are not covered under this limited warranty. Defects or damages due to the misuse, non-observance of safety standards, or non-observance of EPA chemical guidelines are not covered under this limited warranty. Please read and follow the instructions and heed warnings stated in the operating manual and on the Hydra 200™.

The Honda Motor is covered by a 2 year warranty by Honda Motor Corp. A copy of this warranty is included in the enclosed Emission Control sheet in the motor manual.

Dramm Corporation makes no other further warranty, expressed or implied, and all other or further warranties, including any warranties of merchantability or fitness for a particular purpose are expressly excluded.

In no event shall the manufacturer(s) or Dramm Corporation be liable for loss of product, profit or any other special, incidental or consequential damages including, but not limited to, plant damage, property, or persons.

Dramm Corporation makes no warranty, expressed or implied, in regard to the efficacy of any pesticide or other chemical which may be applied using the Hydra Sprayer.

This warranty begins on the date of original purchase. This warranty is void if there is no proof of purchase or warranty registration on file. Mail the warranty registration card to the Dramm Corporation and keep the bill of sale or invoice. If warranty service is required, please include a written description of the equipment malfunction, a return address and telephone number. The Hydra 200™ must be thoroughly cleaned of all chemical residue and sent prepaid to:

Hydra Sprayer Service
c/o Dramm Corporation
2000 North 18th Street
Manitowoc, WI 54220

920.684.0227

information@dramm.com • www.dramm.com

WARNING

Hydra 200G

- This unit is not designed for over-the-road use or highway towing. Do not exceed 5 mph.
- Clean after every use with warm soapy water and then rinse with clean water.
- Wear protective clothing; respirator, hood, gloves and boots when mixing and spraying chemicals.
- Do not spray into the wind. Avoid the drift of solution sprays.
- Do not direct the spray or spray gun at yourself or anyone else.
- Be certain all hoses and connections are secure prior to using the Hydra.
- Avoid dry operation, since the spray solution acts as a pump lubrication.
- Relieve the pressure before removing the hoses or spray gun.
- Apply all chemicals according to EPA Guidelines.
- Store in a clean, dry location- away from children and unauthorized personnel.
- Remove all hoses and drain the pump prior to storage.
- Do not drag the hoses over sharp objects or bend excessively.
- Repair or replace all damaged or broken hoses before using the Hydra 200.
- Before servicing the unit, disconnect the Hydra 200 from the power source.
- Do not store mixed chemicals. Use all of the chemical mixture immediately.
- Do not adjust the Pressure Regulator Valve past its stop.

Introduction

The Damm Hydra™ 200 is a hydraulic sprayer that offers a variety of flow rates with a variety of pressures to allow for maximum flexibility. The Hydra 200 can apply all formulations of chemicals including insecticides, fungicides, Insect growth regulators, plant growth regulators, and disinfectants. The Hydra can output all formulations without damage or corrosion to the pump.

The Damm Hydra 200 includes a 5.5 HP Honda gasoline motor and a close-coupled pump capable of 7 gpm output and 550psi. 200 gallon tank, with optional 20 gal tank for smaller areas, maneuverable cart, a convex reel with a separate lock and variable drag system, 150 – 300 feet of high pressure spray hose, and a variable pattern trigger spray gun.

Assembly & Preparation

Your 200 comes to you ready to spray. After removing the sprayer from the crate, check the tank for any additional parts and accessories. Connect the spray gun to the hose using the quick disconnect. Your machine is now ready for use.

START UP

1. Either switch on the electric motor or Pull-start the Honda motor by setting the motor speed to fast & engaging the choke. *for more on motor operation see the motor manual pg 15.*
2. Fill the sprayer to the desired level. **Do Not** operate the sprayer empty for more than a few seconds. The water acts as a coolant and lubricant for the pump and damage may occur.
3. Start the sprayer with the pressure control knob in the **START** position. (A). **Do Not** attempt to start the sprayer under pressure as this will stall the motor and cause an overload condition.
4. After starting the sprayer allow it to run with the pressure control knob in the start position. This will remove any air from the system, which can harm the pump.
5. Engine speed should not exceed 3,500 RPM. Maximum speed should be set using the adjusting screw located directly above the throttle lever of engine.

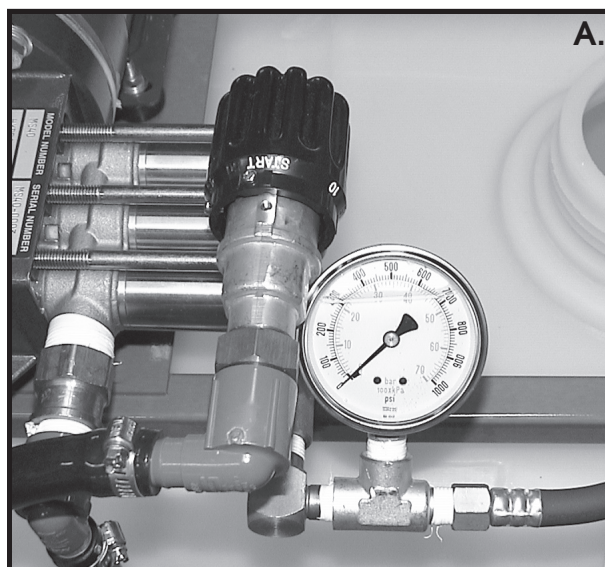

NOTE

- Always start and shutdown your sprayer with the pressure regulator in the **START** (priming) position.
- Keep inlet filter clean.
- Always rinse the tank and flush the pump with clean water after each use.

Operation

SPRAY OPERATION

1. After following the start up, to increase the spray pressure, turn the pressure control knob to the desired setting. (B) You may use any of these settings for spraying, as the unit will operate properly at all settings.
2. To begin spraying, pull the lever to the gun. A latch is provided to hold the level open to reduce operator fatigue. (C)

CAUTION: Do not direct the spray at yourself or others, as injury may occur. On higher pressure settings, the spray stream may cut or inject spray under your skin. Always wear proper personal protective gear when spraying.

3. Spray Pattern: Adjustment of the spray pattern is made using the lever on the side of the gun. The pattern will adjust from a straight stream to a fine cone mist. (D)
4. Hose Reel: The Hydra MultiSpray comes standard with a variable drag lockable hose reel. The reel may be locked in position to prevent the hose from unwinding further than wanted. (E) The variable drag on the reel places variable tension on the reel to prevent freewheeling of the reel during unwinding. The drag has a lever to activate it. A nut allows for tension adjustment. (F)

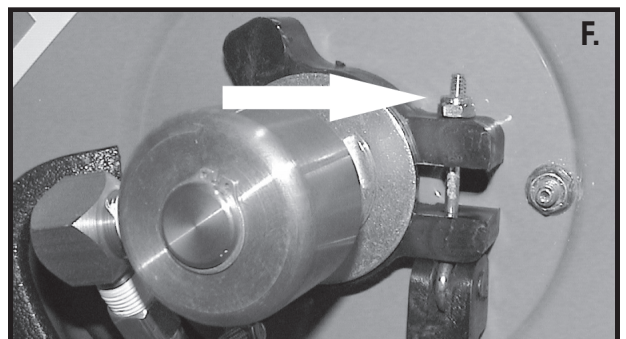
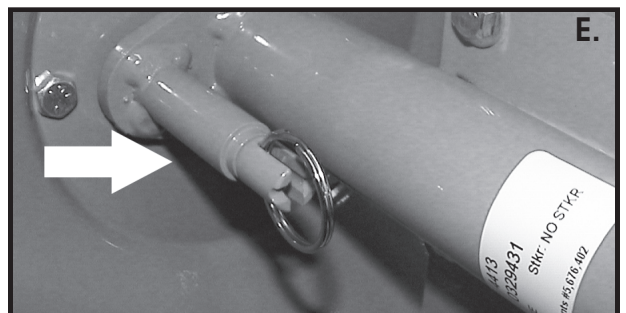
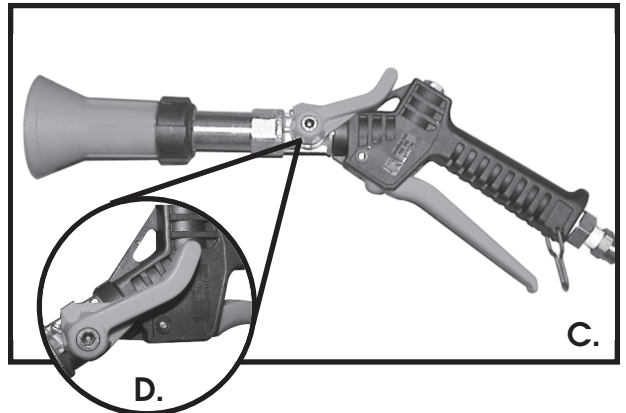
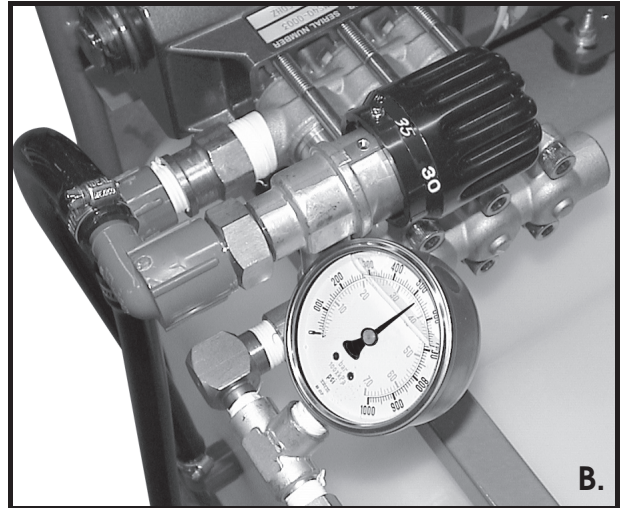

SHUT-DOWN

1. After spraying until the tank is empty, turn the unit off.
2. Add clear water to the tank. Start the machine and spray until empty flushing out the pump hose and gun.
3. Clean any residue from the unit.
4. Return the regulator to the **START** position.
5. Store the unit in a clean dry place.
6. **Do Not** allow the unit to freeze as any water left in the unit will expand and damage the machine.

Chemical Mixing Procedure

1. Fill the sprayer tank at least 3/4 full with water *ONLY*.
2. Dilute (mixing to dissolve) chemicals with water in a 5 gallon bucket. Never put concentrated chemical formulations directly into the tank without diluting with water.
3. Start sprayer with pressure regulator in **START** (priming) position to begin agitation process prior to adding chemical to sprayer tank.
4. Pour chemical and water mixture (slurry) into the sprayer tank, filled 3/4 full of water, after agitation has begun.
5. Fill remainder of sprayer tank with water.

Maintenance & Cleaning

1. **Periodically check the pump oil level (G)**
If it is below the indication, add oil through the filler (H). Oil should be changed after the first 50 hours of operation. Use SC grade SAE10W-30 oil.

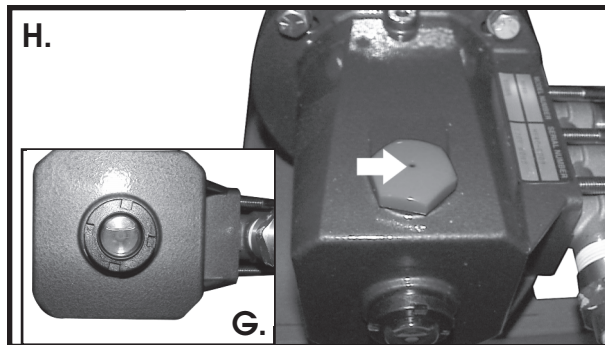

2. **Periodically lubricate the grease fittings on the wheels** with a good grade of bearing grease to extend the wheel bearing life.

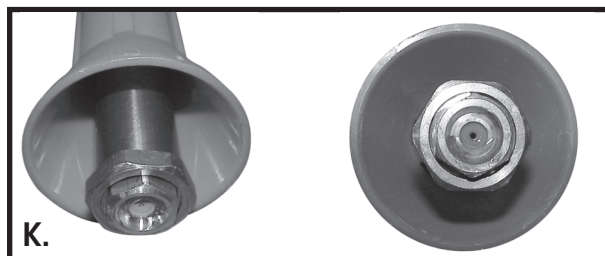

3. **Replace the spray gun tip every season.**
As the hole in the tip gets larger the spray pressure drops and degrades the quality of the spray. (K)

4. **Thoroughly clean the in-line filter, tank and machine on a weekly basis.**



5. To drain tank, rotate the drain valve (L.) 90° allowing flow from the drain hose. To completely drain tank, remove the lower housing of the in-line filter (M). ***After draining, clean the filter, replace the housing and close the drain valve (L) to ensure that upon refilling the tank- the chemical will not drain out of the unit.**

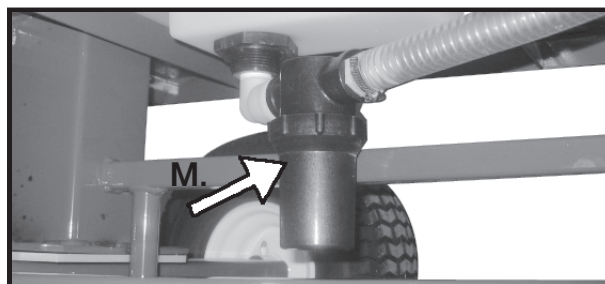

Hydra 200 Cart Assembly

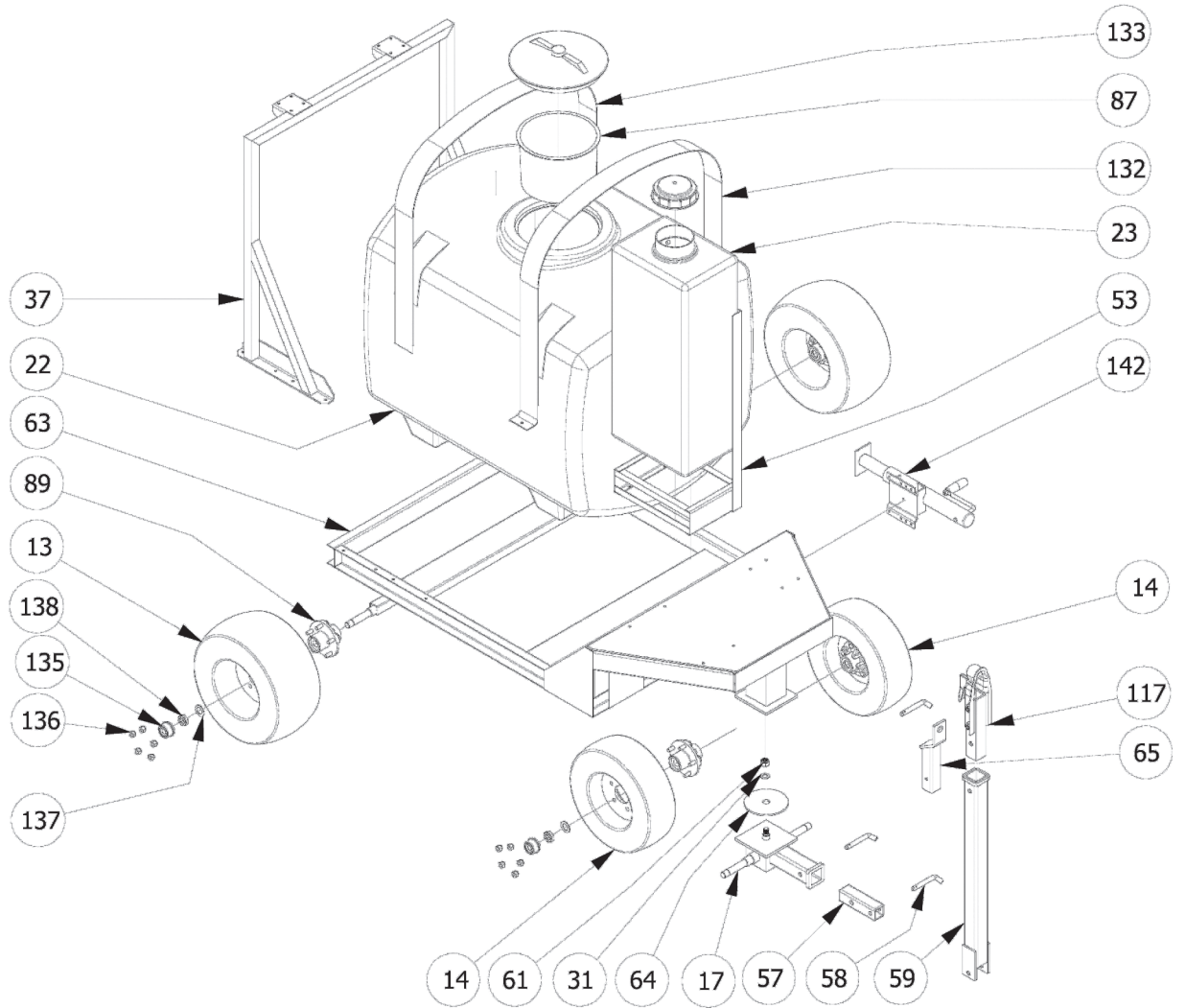

Hydra 200 Cart Assembly Parts List

Parts List			
ITEM	PART NUMBER	DESCRIPTION	QTY
13	12207	Tire & Wheel 18.5 x 8.9	2
14	12111	Tire & Wheel 16.5 x 4.8	2
17	D12007 SINGLE STEER	200G SINGLE STEER ASSM	1
22	PC0200 37S	TANK 200 GALLON W/SUMP	1
23	SP0020-OM 1	TANK 20 GALLON VERT	1
31	98017A220	WASHER FLAT 3/4	1
37	D12005	FRAME REEL BRACKET 200G	1
53	D12008A	TANK BRACKET 200G VERT	1
57	D12040	DRAW BAR EXTENSION	1
58	2507T51	RECEIVER HITCH PIN	3
59	D12039	Draw Bar Hydra 200G	1
61	90619A425	NUT 3/4-10 LOCK	1
63	D12006 Frame Single Front	FRAME HYDRA 200G	1
64	D12006 pivot bearing	PIVOY BEARING HYDRA 200G	1
65	2507T21	HYDRA 200G "OPTION"	1
87	10536	200G STRAINER BASKET	1
89	572051	HUB W/BEARINGS	4
95	10522	LID 20 Gallon	1
111	200G LID	LID 200G TANK	1
117	D12029	HITCH COUPLER ASSM 200G	1
132	PC0200 SBPS	TANK STRAP short	1
133	PC0200 SBPS cut	TANK STRAP CUT	1
135	572051 hub cap	BEARING CAP	4
136	572051 lug nut	LUG NUT	20
137	783931 Washer	WASHER BEARING	4
138	783931 Castel Nut	BEARING NUT	4
142	44064	SWIVEL JACK 1500	1

Hydra 200 Hose Reel Assembly

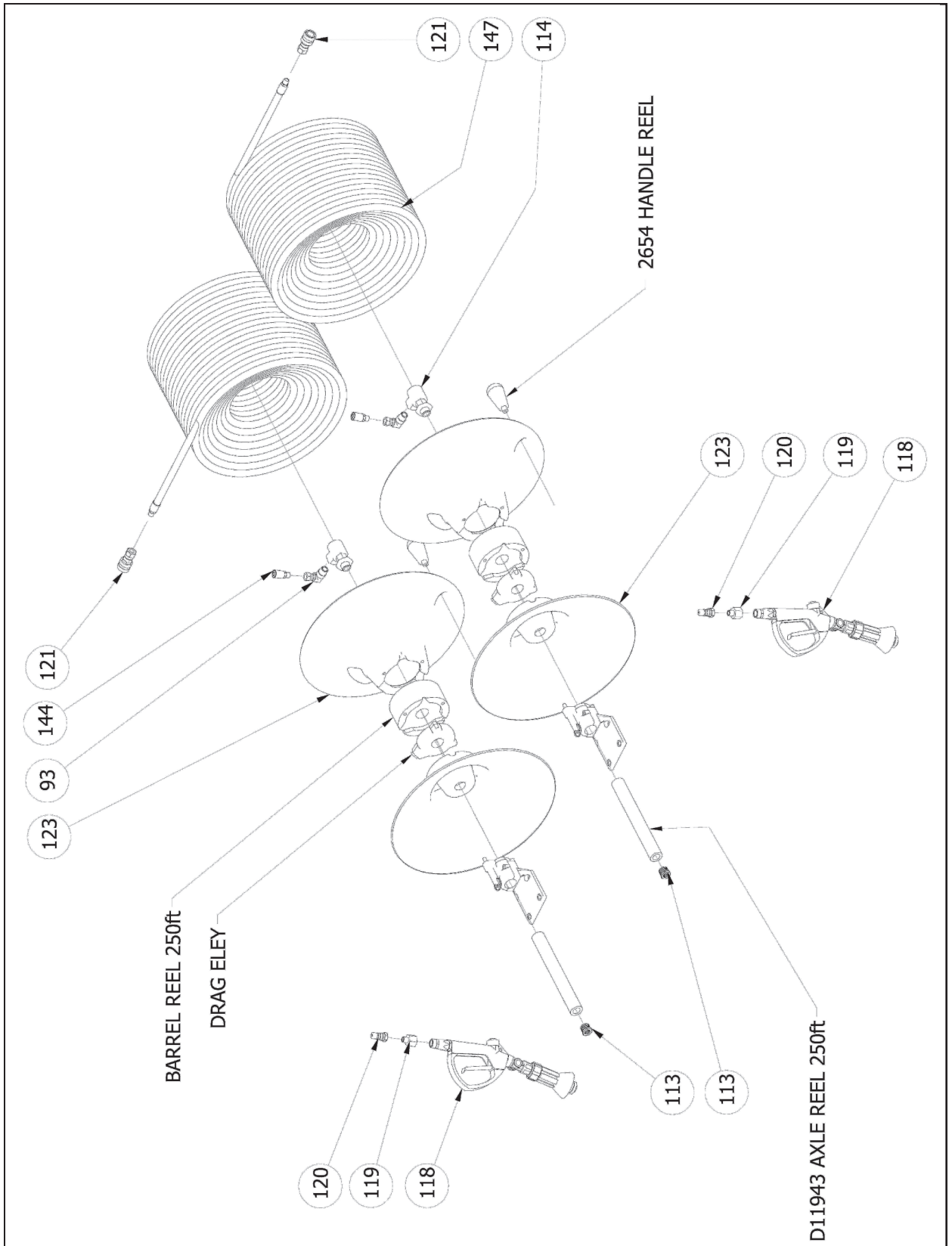

Hydra 200 Plumbing Assembly

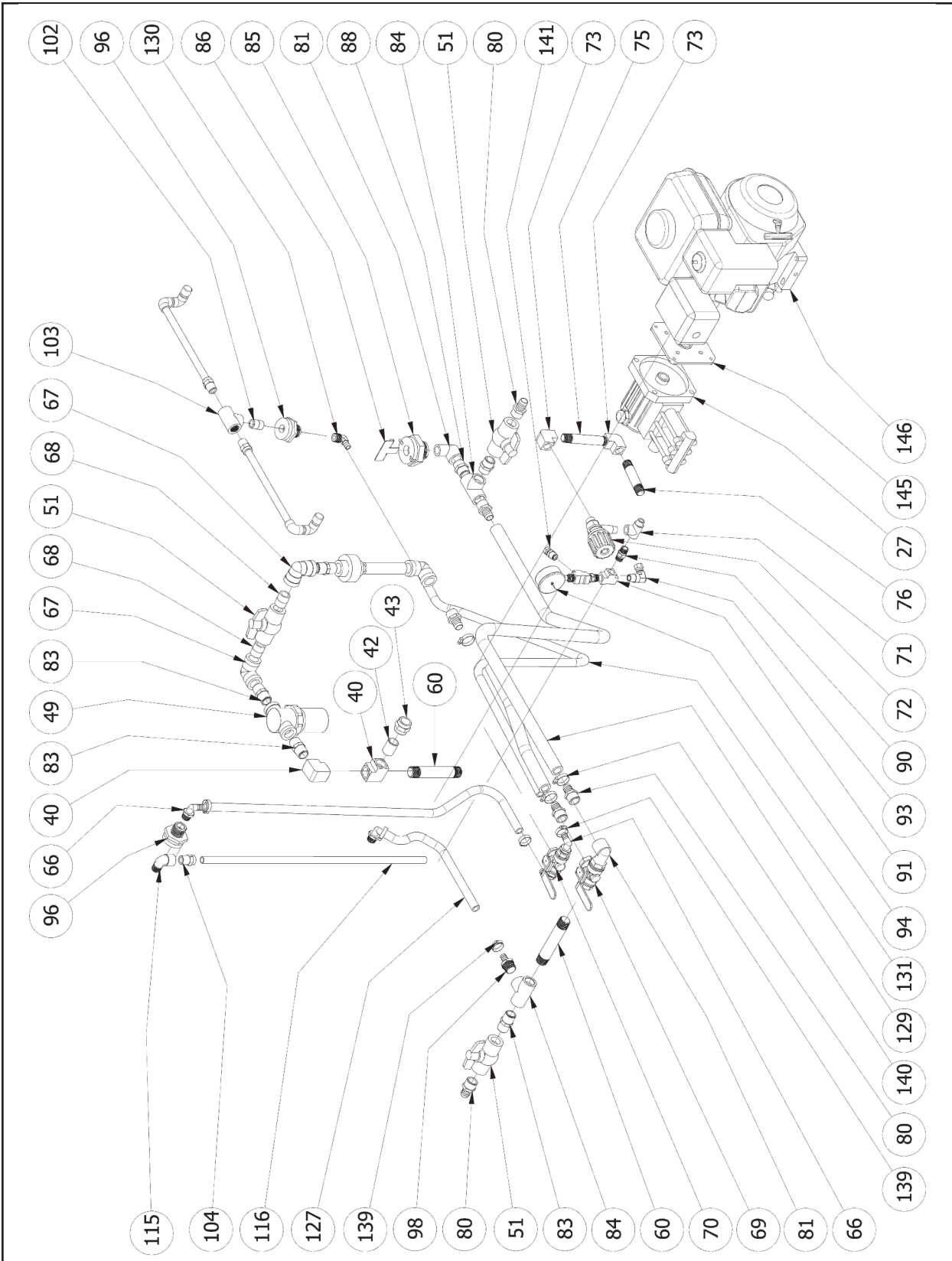

Hydra 200 Plumbing & Hose Reel Parts List

Parts List D12027 plumbing				Parts List D12027 plumbing			
ITEM	PART NUMBER	DESCRIPTION	QTY	ITEM	PART NUMBER	DESCRIPTION	QTY
27	MSD41	PUMP ASSM HYDRA	1	93	220104	ELBOW SWIVEL 3/8 x 1/4 St z	3
40	220101	ELBOW 3/4 FPT, BR	2	94	260005	GAGE 0-1000 PSI, 2 1/2 SST	1
42	220052	NIPPLE 3/4NPT CLOSE BR	1	96	220500	BULHEAD FITTING 3/4FPT	2
43	220043	COUPLING HEX 3/4NPT BR	1	98	5372K126	BARB 1/2 x 3/4NPT NY	1
49	290002	STRAINER-T, 40 MESH, POLY	1	102	220005	NIPPLE CLOSE 1/2 CPVC	1
51	230026	VALVE BALL 3/4 DURA, PVC	3	103	220602	TEE THREADED 1/2 PVC	1
60	220017	NIPPLE PIPE 3/4PT x 5 1/2in, BR	2	113	220002	NIPPLE HEX 1/2 x 1/4 BR	2
66	5372K325	BARB ELL 1/2 x 1/2MPT NY	4	114	2652	SWIVEL - REEL BR (ELEY)	2
67	220107	ELBOW 3/4 THRD PVC	3	115		ELBOW ST 1/2PT PVC	1
68	220012	NIPPLE 3/4 x 2 1/2, PVC	2	116	CPVC 05 x 25	CPVC 1/2 x 25	1
69	4093T24	Valve Diverter 3/4" BR	1	118	MS40 TG M	TRIGGER GUN HYDRA METAL	2
70	4093T23	Valve Diverter 1/2" BR	1	119	220055	ADAPTER 1/2PTF x 1/4PTM BR	2
71	542258	TEE MALE RUN 3/8 BR	1	120	220300	QUICK DISC, MALE	2
72	546849	UNLOADER VALVE HYDRA	1	121	220301	QUICK DISC, FEMALE	2
73	220100	ELBOW 1/2 NPT, BR	2	123	240004A	REEL ASSM 250	2
75	4568K179	NIPPLE 1/2NPT x 5 BR	1	127	20G suction	TUBE 1/2 PVC	1
76	4568K177	NIPPLE 1/2NPT X 4 BR	1	128	20G agitation	TUBE AGITATION 1/2 PVC	1
78	220700	UNION 3/4, PVC	1	129	SUCTION 200G	SUCTION HOSE 200G	1
79	220031	NIPPLE 3/4 X 4 1/2 SCH80 PVC	1	130	220201	BARB ELL 1/2 x 1/2MPT BR	1
80	220203	BARB 3/4 x 3/4MPT NY	6	131	AGITATION 200G	TUBE AGITATION 200G 1/2 PVC	1
81	220108	ELBOW 3/4PT STREET PVC	2	134	200G suction 13 5	SUCTION HOSE 13-1/2	1
83	8203	NIPPLE HEX 3/4 PVC	4	139	220401	CLAMP, HOSE 5/16W -1 H	6
84	220606	TEE 3/4 FPT PVC	2	140	220402	CLAMP HOSE 5/16W X 1-1/4H	3
85	220501	BULHEAD FITTING 3/4FPT	1	141	220032	SWIVEL 3/8NPT x 1/4NPSM	1
86	D11305	ANTI-VORTEX	1	143	220200	BARB 3/8 x 1/4MPT, BR	4
88	220004	HEX NIPPLE 3/4 NY	2	144	220551	FERRULE .675 BR	4
90	220006	NIPPLE HEX 3/8 BR	2	145	046271	FLANGE ADAPTER PUMP	1
91	220603	TEE 3/8 NPT BR	2	146	450000	HONDA 5.5 HP ENGINE	1
92	220001	BUSHINH HEX 3/8 x 1/4 BR	1	147	250002 250ft	PRESSURE LINE 3/8 - 250ft	2

Hydra 200 OPTIONAL 20 gallon Tank Valve Operation

The HYDRA200G has the option of an extra, 20 gallon tank for smaller applications, or for use as a nurse stock tank for the larger tank.

Using the set of valves at the front of the unit, the operator can choose which tank is the source and which tank is the bypass/agitation recipient. It is possible to draw solution from either tank and return the bypass to that same tank (for agitation) or to the other tank (for solution transfer), based on valve position.

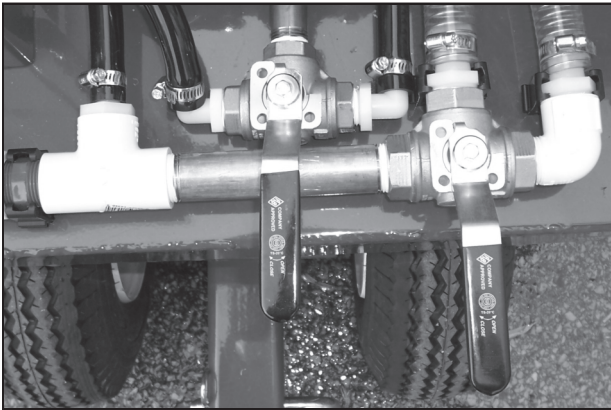

Both valves turned to the FRONT will operate the small tank.

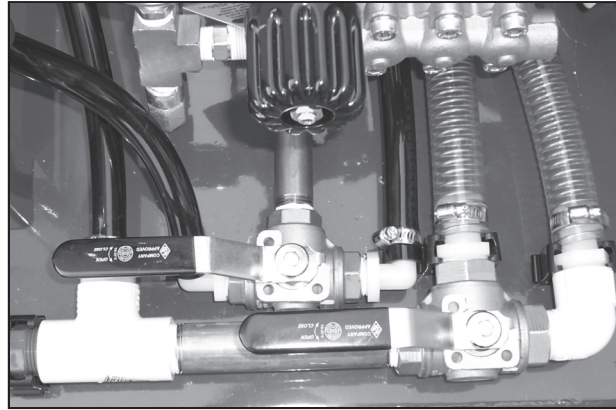

Both valves turned to the RIGHT will operate the large tank.

Hydra 200 Agitation System

Your HYDRA200G sprayer includes a hybrid agitation system that combines fluid recirculation with mechanical agitation. By employing optimally placed bypass return and nozzles, to increase motion in the tank, the Hydra will keep the most stubborn chemicals in suspension/solution.

Periodically check that these nozzles are not clogged and free of debris to ensure proper agitation.

Hydra 200 Brake Maintenance

INTENDED USE

This swivel jack with sturdy 2 1/4" tube is reliable and very easy to use. The sidewind internal gear design and large, grooved comfort handle makes cranking easy, while a deep-seated snap ring adds side load capacity. A durable 1/2" pull pin activates the swivel mechanism, allowing you to swing the jack up and out of the way when not in use.

OPERATION

To activate the swivel function on the jack, pull the pin and swivel jack into desired position.

MAINTENANCE

- **Maintain your Jack.** It is recommended that the general condition of any jack be examined before it is used. Keep your jack in good repair by adopting a program of conscientious repair and maintenance. If jack is damaged, discontinue use of the jack.
- This jack is pre-greased for easy operation. This jack includes a grease zerk for easy lubrication as needed.

WARNING

Swivel Bolt-On Jack

- This jack is designed for vertical loading. Excessive side forces may cause failure and or injury.
- Before moving trailer, crank jack to its lowest position.
- Store idle jack. When jack is not in use, store it in a secure place out of the reach of children.
- Inspect jack for good working condition prior to storage and before re-use.

200 Spray Gun

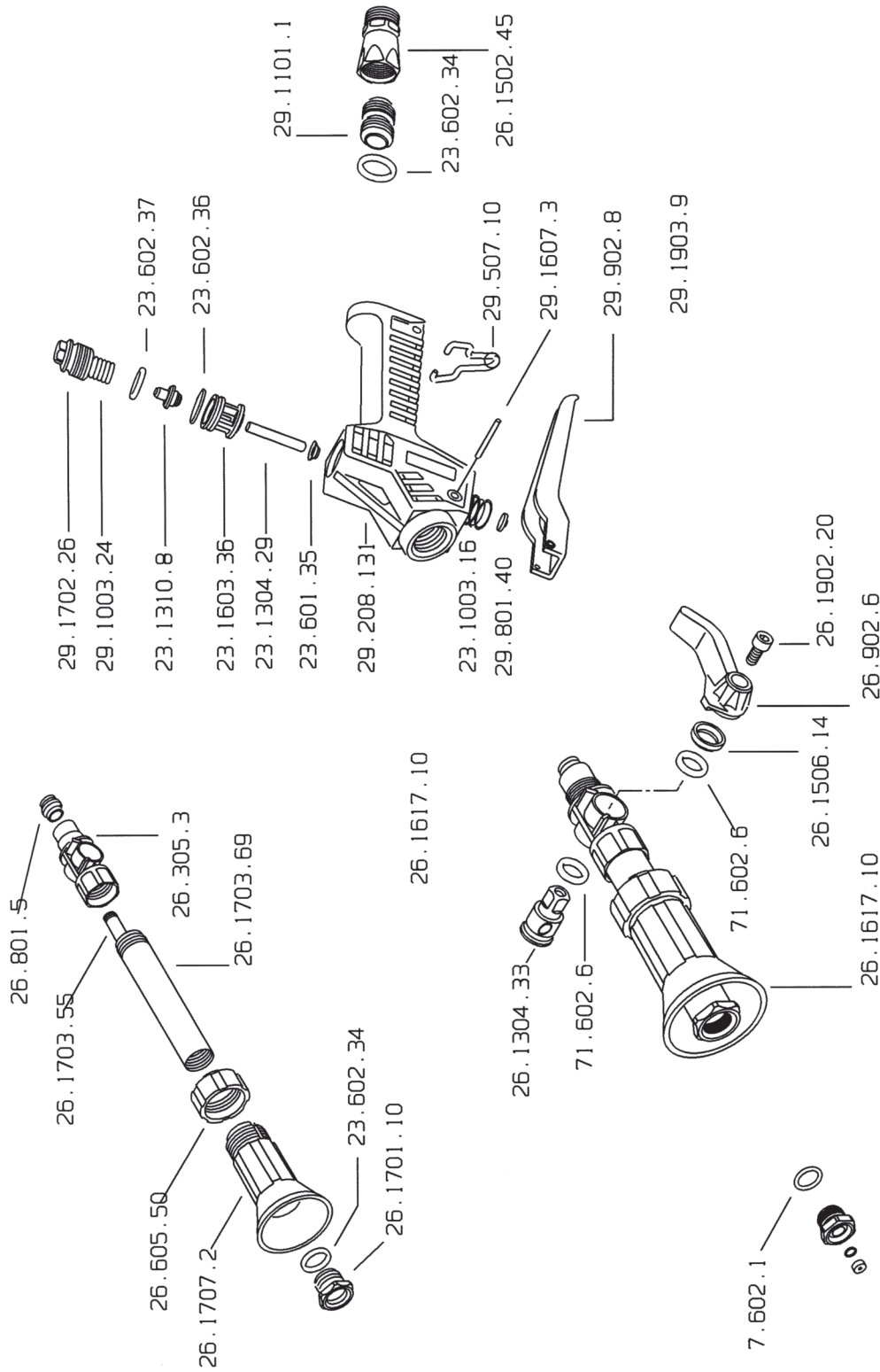

Spray Gun Parts List Model MSO40

PART #	DESCRIPTION	QUANTITY
23.1003.16	Trigger Spring	1
23.1304.29	Push Pin	1
23.1310.8	Plug	1
23.1603.36	Flow Regulator Body	1
23.602.34	O-Ring	2
23.602.36	O-Ring	1
23.602.37	O-Ring	1
26.1304.33	Directional Switch	1
26.1506.14	Spacer	1
26.1617.10	Complete Flow Tube Assembly	1
26.1701.10	Nozzle	1
26.1703.55	Narrow Pattern Tube	1
26.1703.69	Flow Tube	1
26.1707.2	Spray Shield	1
26.1902.20	Screw	1
26.305.3	Spray Pattern Control Body	1
26.605.50	Wing Nut	1
26.801.5	Spacer	1
26.902.6	Spray Pattern Control Valve	1
29.1003.24	Spring	1
29.1101.1	Nipple	1
29.1607.3	Trigger Pin	1
29.1702.26	Plug	1
29.1903.9	Complete Trigger Valve Assembly	1
29.208.131	Valve Body	1
29.507.10	Trigger Locking Clip	1
29.801.40	Stopper	1
29.902.8	Trigger	1
71.602.6	O-Ring	1

MSD41 Crank Case and Inlet Valve

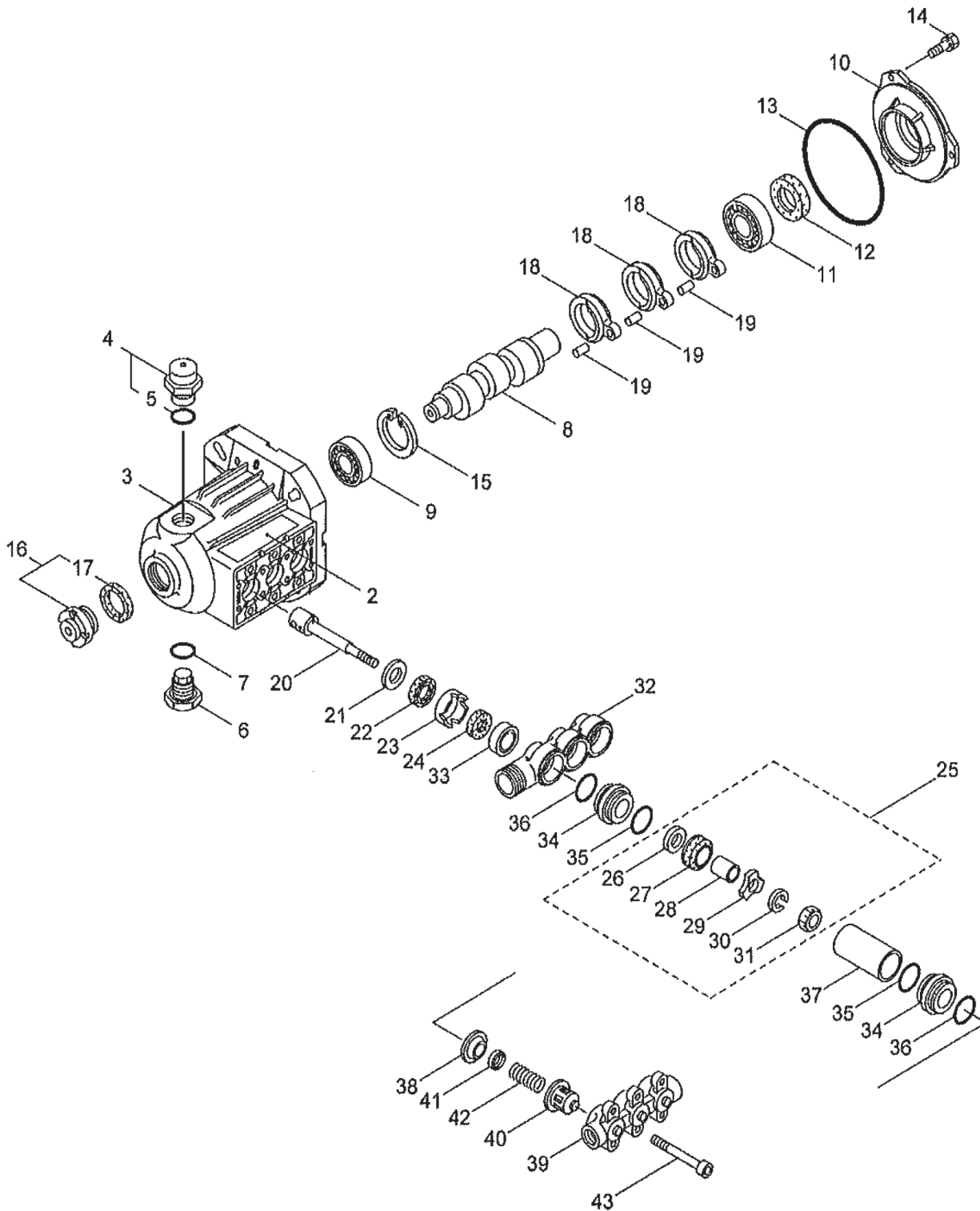

Crank Case and Inlet Valve Parts List

REF #	PART #	DESCRIPTION	Q'TY.	NOTES
2	548895	Label	1	MSD41
3	547333	Crankcase	1	
4	547961	Oil Filler Cap, Assy.	1	Incl.5
5	014179	O-Ring	1	P20
6	044842	Plug	1	
7	014179	O-Ring	1	P20
8	545981	Crankshaft	1	7.0X19.07
9	015710	Bearing	1	#6204
10	547153	Bearing Case	1	2SF
11	014488	Bearing	1	#6006
12	055337	Oil Seal	1	D30428
13	014041	O-Ring	1	S100
14	547161	Bolt	3	M6X14
15	012385	Snap Ring	1	
16	092241	Oil Gauge Assy	1	Incl.17
17	044428	Packing	1	25X34XT2
18	547046	Connecting Rod	3	2SF38MM
19	016948	Piston Pin	3	9X22
20	541809	Piston Rod	3	
21	020017	Washer	3	17X24XT1.2
22	025461	Oil Seal	3	S10.5247
23	044869	Seal Retainer	3	
24	011402	Oil Wick	3	10X19X5
25	639503	Inlet Valve Assy	3	Incl.26-31
26	014122	Inlet Valve Seat	3	6.1X20XT2.8
27	116121	Piston Packing	3	
28	027348	Spacer	3	6X8.5X10.5
29	119917	Piston Retainer	3	
30	015849	Spring Washer	3	M6
31	046365	Nut	3	M6
32	545944	Manifold A	1	
33	540670	U Packing	3	
34	546860	Adapter	6	
35	015862	O-Ring	6	P21
36	023172	O-Ring	6	P22
37	541811	Cylinder Pipe	3	25X28.5XL43
38	044881	Valve Seat	3	
39	544499	Manifold B	1	
40	044565	Valve Sack	3	
41	548608	Valve	3	16X1.5
42	541062	Spring	3	0.6-15L
43	544090	Cap Screw	6	M8X110X28

MSO40E Pressure Regulator Valve

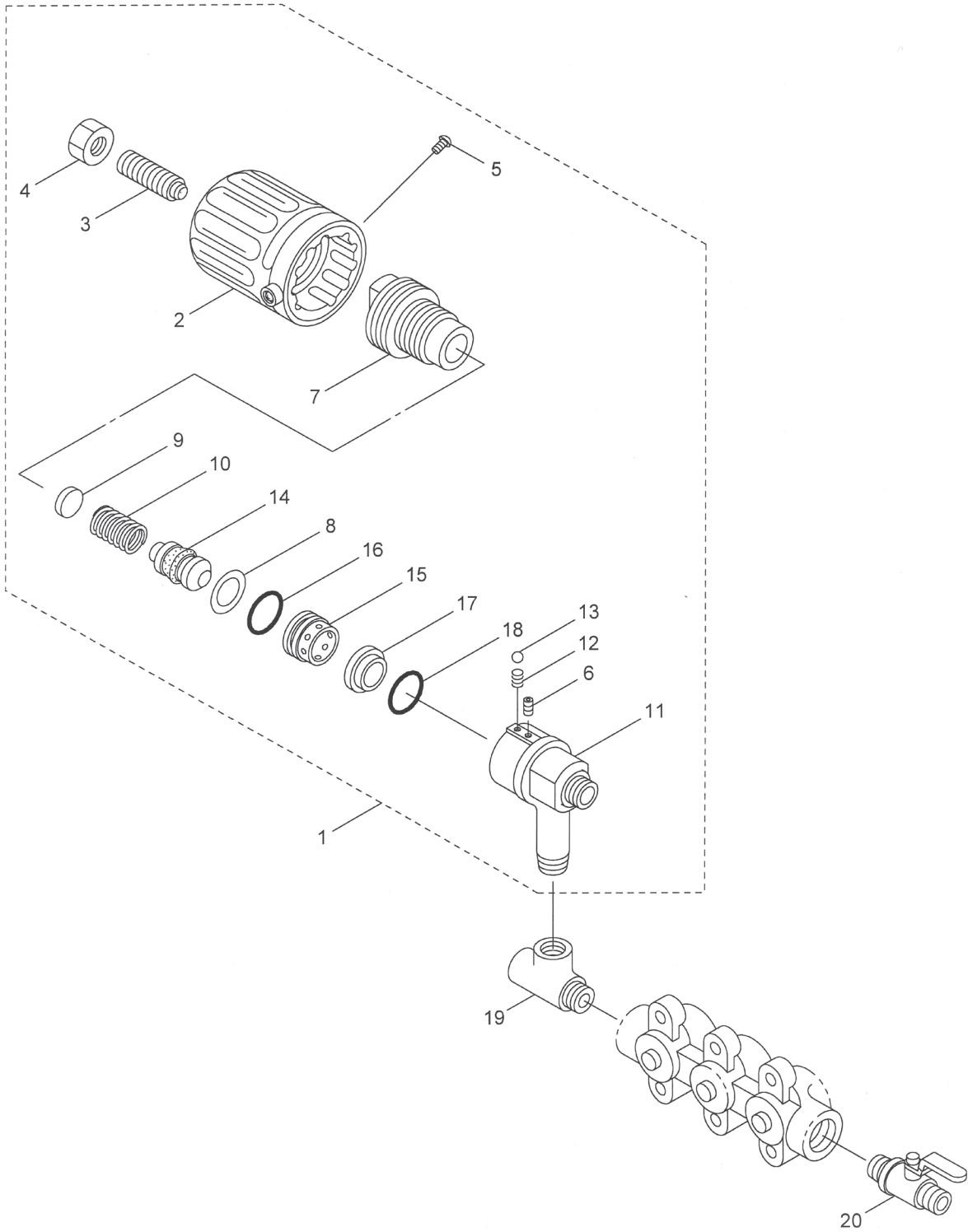

Pressure Regulator Valve Parts List

ITEM #	PART #	DESCRIPTION	QUANTITY
2-1	546849	Pressure Regulator Valve	1
2-2	540936	Grip	1
2-3	088913	Cap Screw	1
2-4	081039	Nut	1
2-5	087483	Screw	2
2-6	088912	Cap Screw	1
2-7	106495	Guide	1
2-8	106499	Washer	1
2-9	541769	Retainer	1
2-10	109298	Spring	1
2-11	546500	Body	1
2-12	107221	Spring	1
2-13	106498	Ball	1
2-14	543591	Piston Assembly	1
2-15	103306	Sleeve	1
2-16	019261	O-Ring	1
2-17	543507	Valve Seat	1
2-18	019261	O-Ring	1
2-19	542258	Tee	1
2-20	541796	Cock Assembly	1

Troubleshooting

This power sprayer troubleshooting section shows how to diagnose and resolve problems that may occur in the course of normal operation. If you experience a problem, take the steps indicated for the applicable diagnosis. When you can't determine the cause of a problem or if you have any difficulty, please feel free to contact your nearest dealer or this company's sales office. Please have the following information ready: 1. Model designation 2. Serial number 3. Description of problem (What happened? What were you doing when it happened? What were the conditions when it happened?) For items marked with *, please request adjustment or repair from your nearest dealer or from this company's sales office.

WARNING: Do not change the setting of the screw that is under the cap on the top of the pressure regulator knob. This screw absolutely must not be changed, since that will raise the pressure above rated specifications, damage the machine, and possibly cause injury.

PROBLEM	CAUSE	REMEDY
<ul style="list-style-type: none"> • Suction is Low or Absent <li style="padding-left: 20px;">-Up to Suction Port 	<ul style="list-style-type: none"> • Suction strainer is blocked with debris • Suction hose is damaged or crooked • Suction hose connector gasket is bad • Connection is bad 	<ul style="list-style-type: none"> • Clear and clean • Repair or replace • Repair or replace • Connect properly
<ul style="list-style-type: none"> -Suction & Pressure Parts (Cylinder Part) 	<ul style="list-style-type: none"> • Debris is stuck in inlet or discharge valve • Inlet or discharge valve is assembled improperly • Inlet or discharge valve is damaged or worn • Discharge valve spring is damaged • Piston packing is damaged • O-ring is damaged • Seal & packing are damaged 	<ul style="list-style-type: none"> • Clean • Assemble properly • Repair or replace • Replace • Replace • Replace • Replace
<ul style="list-style-type: none"> -Pressure Regulator Part 	<ul style="list-style-type: none"> • Pressure regulator valve lever in is RUN position • Pressure regulator is stuck 	<ul style="list-style-type: none"> • Return lever to START position • Disassemble & clean
<ul style="list-style-type: none"> • Pressure Will Not Increase <li style="padding-left: 20px;">-Suction & Pressure Part 	<ul style="list-style-type: none"> • Insufficient liquid supplied to intake 	<ul style="list-style-type: none"> • Diagnose under (1)
<ul style="list-style-type: none"> -Pressure Regulator Part 	<ul style="list-style-type: none"> • Pressure regulator valve ball or valve seat damaged • Pressure regulator valve rod is bad • Pressure regulator valve spring bad • Pressure regulator valve spring is damaged or weak 	<ul style="list-style-type: none"> • Replace • Adjust or replace • Repair or replace • Replace

Troubleshooting

PROBLEM	CAUSE	REMEDY
<ul style="list-style-type: none"> • Pressure Falls When Spray Gun is Opened <ul style="list-style-type: none"> -Nozzle -Power Spray 	<ul style="list-style-type: none"> • Nozzle is worn • Nozzle sprays too much liquid • Intake liquid amount is too small 	<ul style="list-style-type: none"> • Replace • Replace with suitable nozzle • Diagnose under (1)
<ul style="list-style-type: none"> • Sprayer Hose Vibrates 	<ul style="list-style-type: none"> • Pressure regulator valve works poorly • Faults in intake or pressure assemblies (stopped up, slack) 	<ul style="list-style-type: none"> • Disassemble or adjust • Clean
<ul style="list-style-type: none"> • Noise 	<ul style="list-style-type: none"> • Loose or worn key • Conrod bolt or other bolt is loose • Bearings are damage • Pressure regulator valve is assembled wrong • Air is being drawn in 	<ul style="list-style-type: none"> • Tighten or replace • Tighten • Replace • Adjust • Inspect
<ul style="list-style-type: none"> • Liquid or Oil Leak 	<ul style="list-style-type: none"> • O-rings are damaged • Seal & packing are damaged • Oil seal is damaged • Clamping or assembly are incorrect 	<ul style="list-style-type: none"> • Replace • Replace • Replace • Disassemble or adjust

Service

The warranty begins on the date of original purchase. The warranty is void if there is no proof of purchase or warranty registration on file. Mail the warranty registration card to the Dramm Corporation and keep the bill of sale or invoice. If warranty service is required, please include a written description of the equipment malfunction, a return address and telephone number. The Hydra 200, must be thoroughly cleaned of all chemical residue and sent prepaid to:

Hydra Sprayer Service
c/o Dramm Corporation
2000 North 18th Street
Manitowoc, WI 54220

800-258-0848
Fax: 920-684-4499

DRAMM

2000 North 18th Street
P.O. Box 1960
Manitowoc, WI 54221-1960 USA
dramm.com

920.684.0227
Order Fax: 920.684.4499
Parts & Service Fax: 920.684.0193

information@dramm.com

800-258-0848